

RAK13800 WisBlock Ethernet Module Datasheet

Overview

Description

RAK13800 is an Ethernet module based on the W5100S-L chip from WIZnet. The module has an embedded Internet Controller Chip that integrates a Hardwired TCP/IP stack with 10/100 Ethernet MAC and PHY. It is truly a one-chip solution for stable internet connectivity.

The RAK13800 TCP/IP stack supports TCP, UDP, IPv4, ICMP, ARP, IGMP, and PPPoE – and it has been proven through various applications over the last decade.

The user can develop an Ethernet application easily by using the simple SOCKETS program instead of handling a complex Ethernet controller. W5100S-L provides four independent SOCKETS to be used simultaneously and 16KB internal memory for RX/TX data communication buffer.

Features

- Based on WIZnet W5100S-L chip
- Support Hardwired Internet protocols
- Support four independent SOCKETS simultaneously
- Support SOCKET-less command
- Support Ethernet Power-down mode & Main Clock gating for power save
- Support WOL (Wake on LAN) over UDP
- SPI Host Interface
- Internal 16Kbytes Memory for TX/RX Buffers
- 10BaseT/100BaseTX Ethernet PHY Integrated
- Support Auto-Negotiation
- Support Auto-MDIX only when Auto-Negotiation mode
- Network Indicator LEDs
- Supply Voltage: 2.97V ~ 3.63 V
- Size: 25 x 50 mm

Specifications

Overview

Board Overview

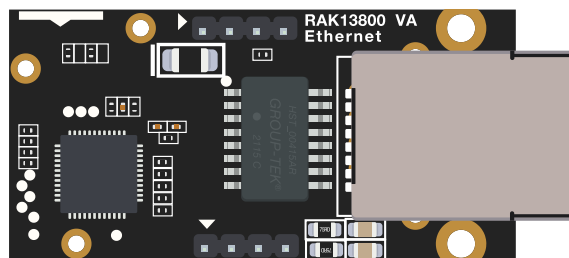

Figure 2: RAK13800 top view

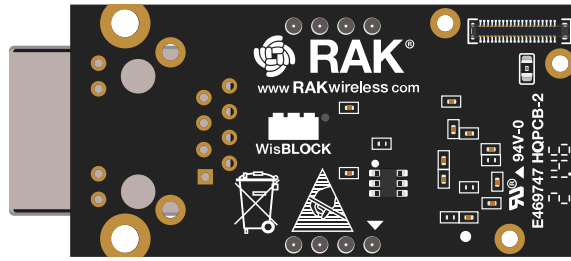

Figure 3: RAK13800 bottom view

Mounting

The RAK13800 module can be mounted to the IO slot of your WisBlock Base board. To illustrate, **Figure 3** shows how RAK13800 can be mounted on the RAK5005-O WisBlock Base Board.

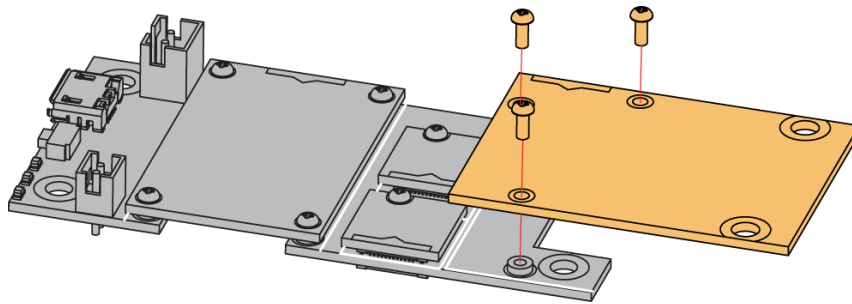

Figure 4: RAK13800 mounting mechanism

Hardware

The hardware specification is categorized into four parts. It shows the pinouts and their corresponding functions. It also covers the electrical and mechanical parameters that include the tabular data of its characteristics. This section also shows the schematic diagram of RAK13800.

Pin Definition

The RAK13800 WisBlock Ethernet module comprises a standard 40-pin IO Connector. The IO connector allows the RAK13800 module to be mounted to a WisBlock Base Board, such as RAK5005-O. The pin order of the connector and the pinout definition is shown in **Figure 4**.

NOTES:

- SPI-related pins, INTn, CSn, RSTn, 3V3_S, and GND are connected to IO Connector.
- +5 V is connected to the WisBlock IO connector to power the WisBlock Base Board with RAK19018 POE.

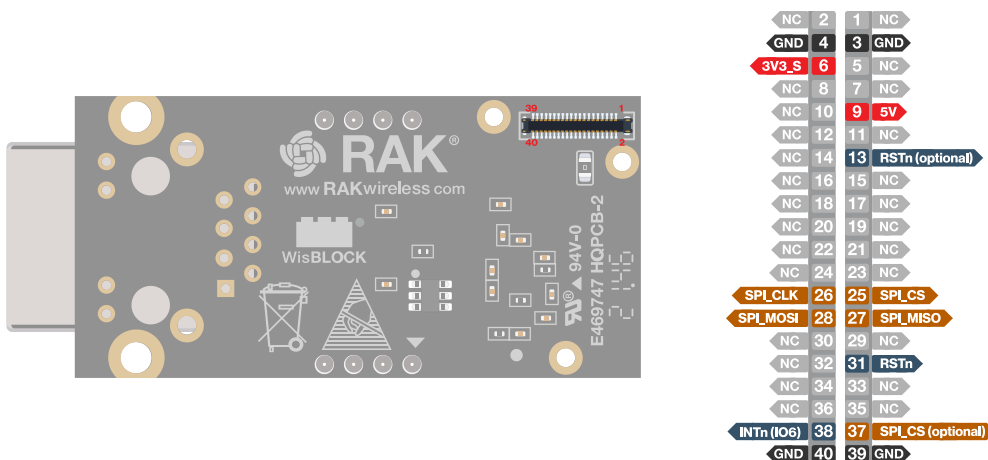

Figure 5: RAK13800 pinout

Electrical Characteristics

Absolute Maximum Ratings

Symbol	Description	Min.	Nom.	Max.	Unit
VDD	DC Supply voltage	-0.5	-	4.6	V
VIN	DC input voltage	-0.5	-	4.6	V
VOUT	DC output voltage	-0.5	-	3.63	V
ESD HBM	Human body model	-	-	2000	V
VESD MM	Man machine model	-	-	200	V
ESD CDM	Charged device mFodel	-	-	500	V

Recommended Operating Conditions

Symbol	Description	Min.	Nom.	Max.	Unit
VDD	Supply voltage	2.97	3.3	3.63	V
IDD1	Supply current	-	132	-	mA

Mechanical Characteristics

Board Dimensions

Refer to **Figure 5** below for the mechanical dimensions of the RAK13800 module.

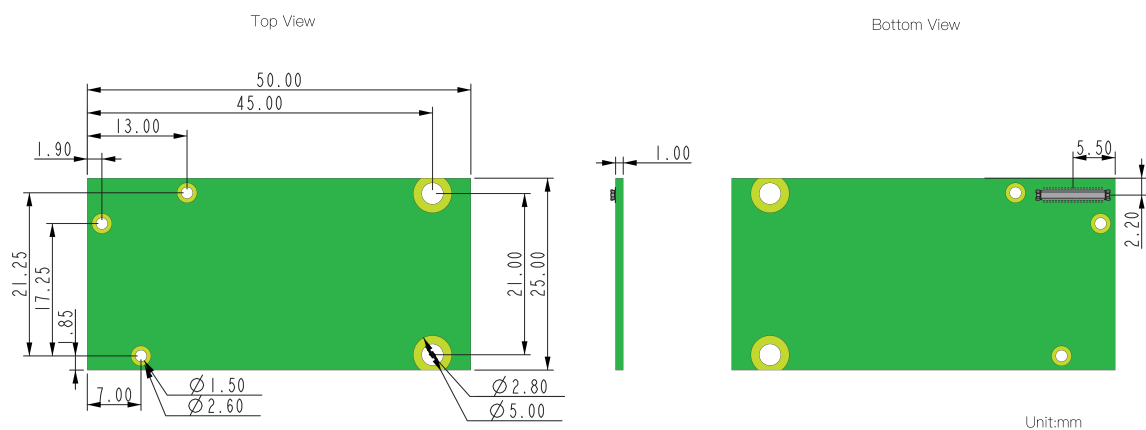

Figure 6: RAK13800 mechanical dimensions

WisConnector PCB Layout

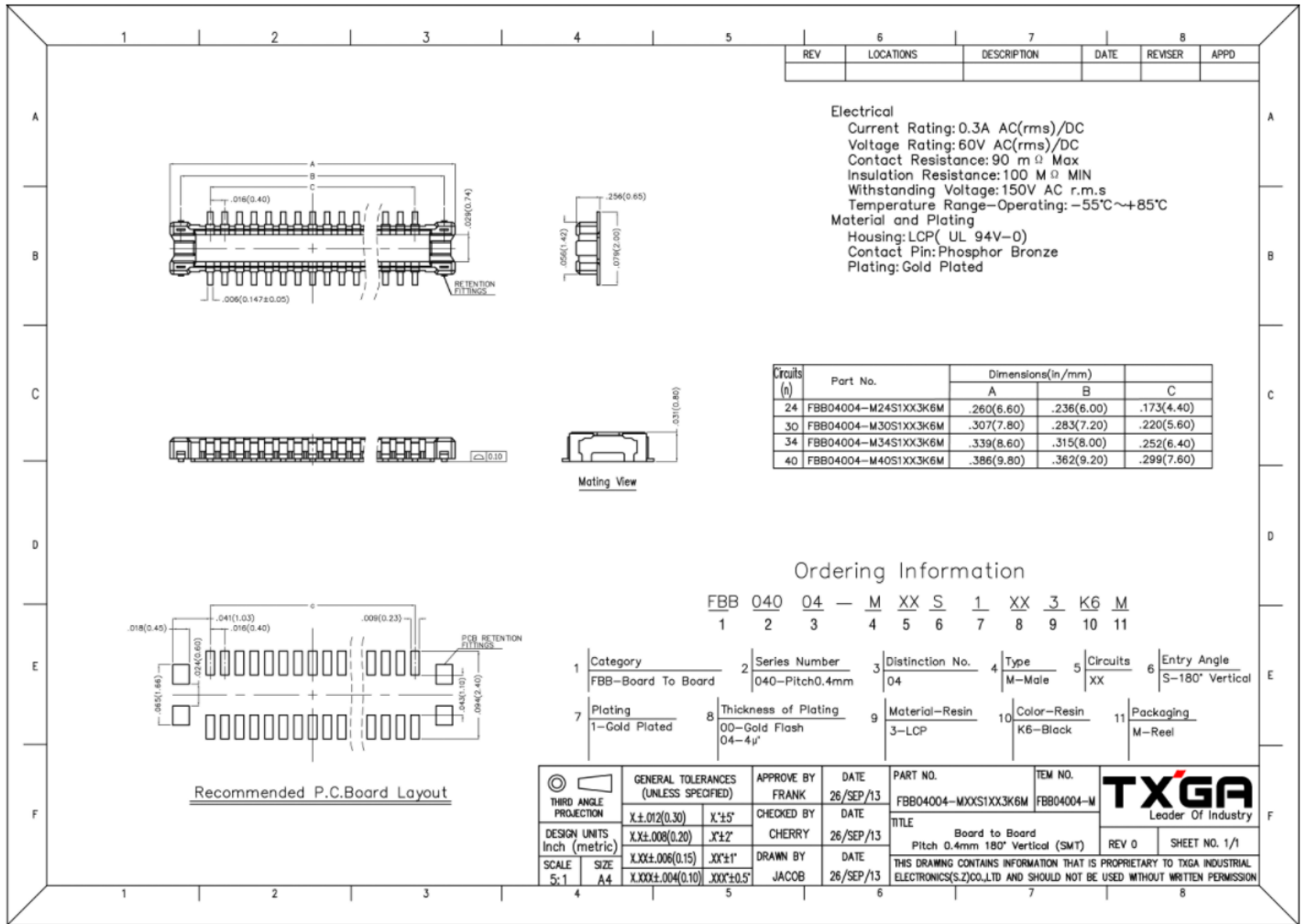

Figure 7: WisConnector PCB footprint and recommendations

Schematic Diagram

Standard WisBlock Connector

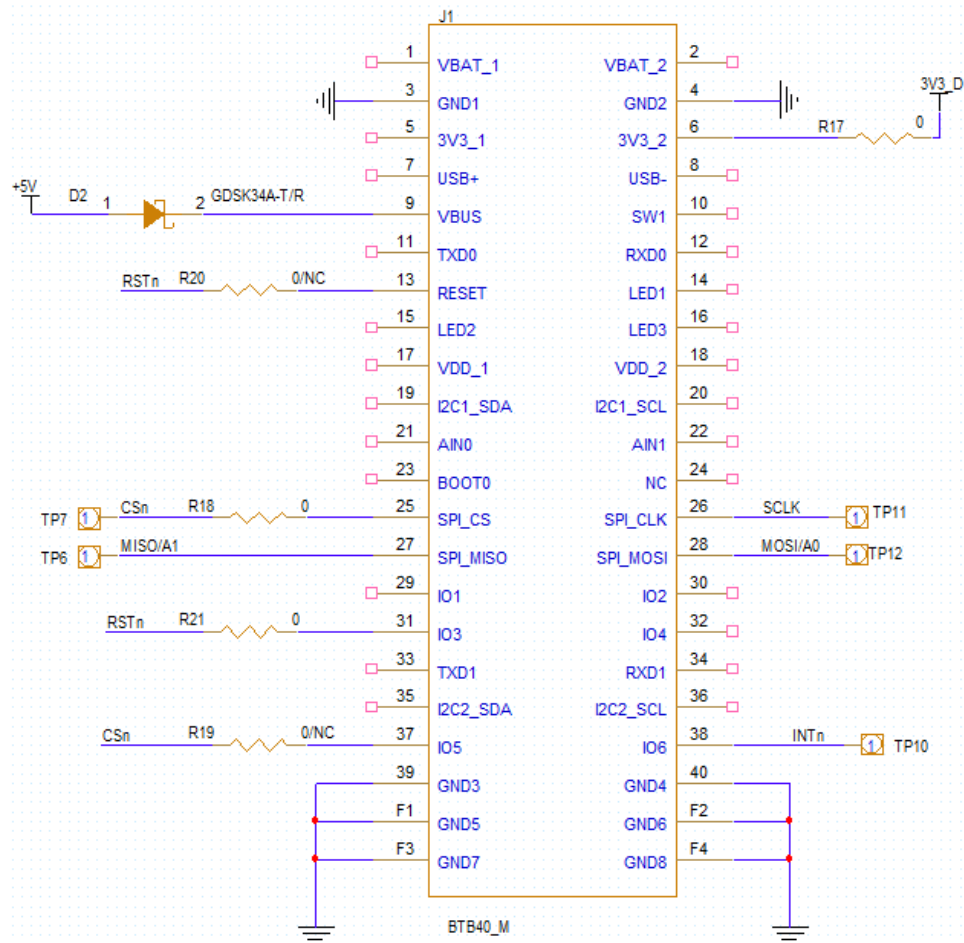

Figure 8: Standard WisBlock connector

WIZnet W5100S-L Ethernet Controller

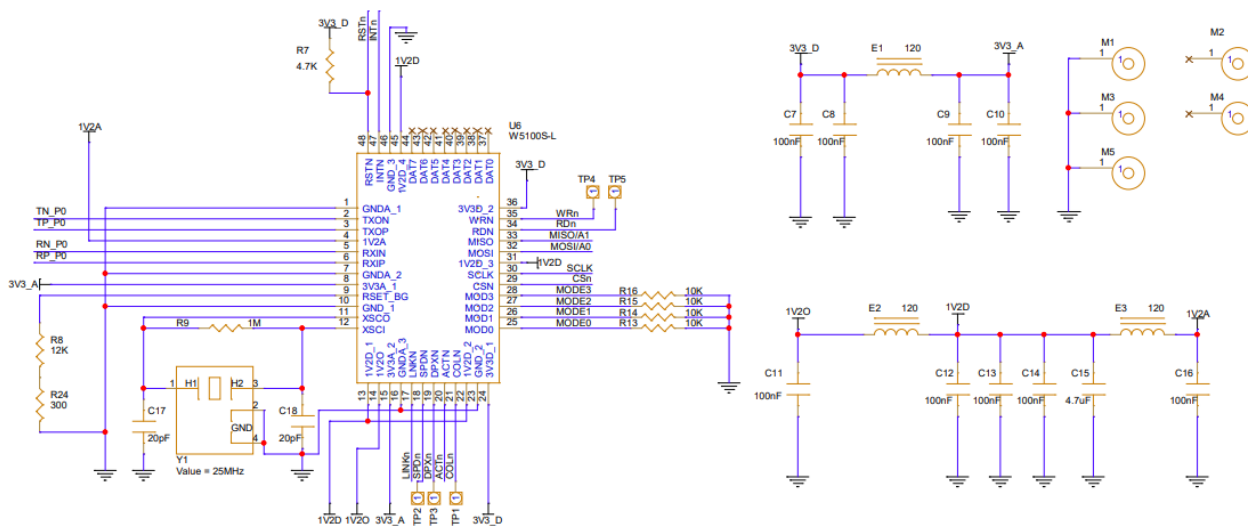

Figure 9: WIZnet W5100S-L Ethernet controller and mounting holes

RJ45 Connector and Ethernet Transformer

T1 is the Ethernet Transformer and J4 is the RJ-45 Connector.

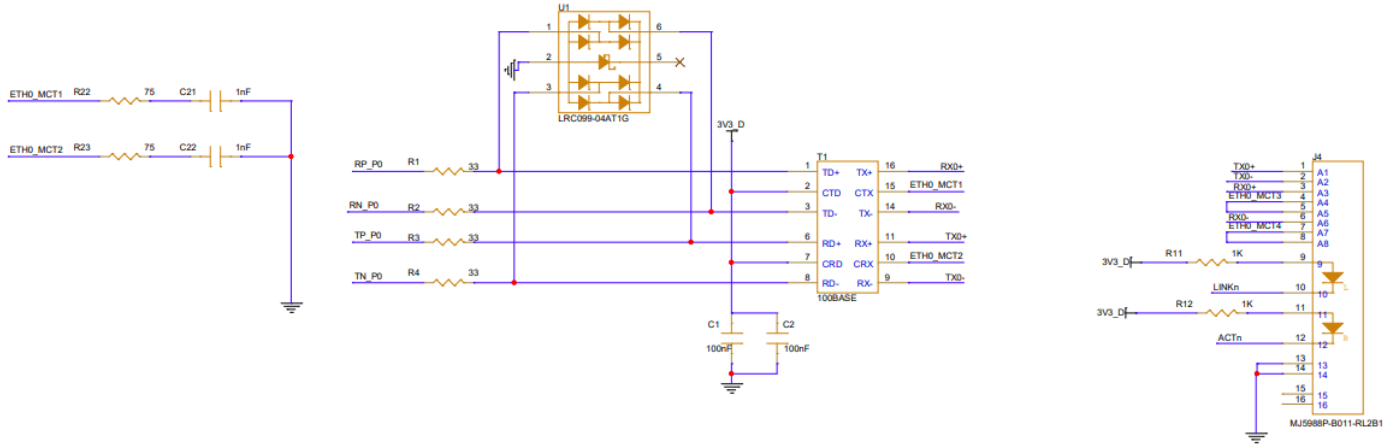

Figure 10: RJ45 connector and Ethernet transformer

Power Connector for RAK19018 POE

J6 is 5 V output and J5 is POE power input.

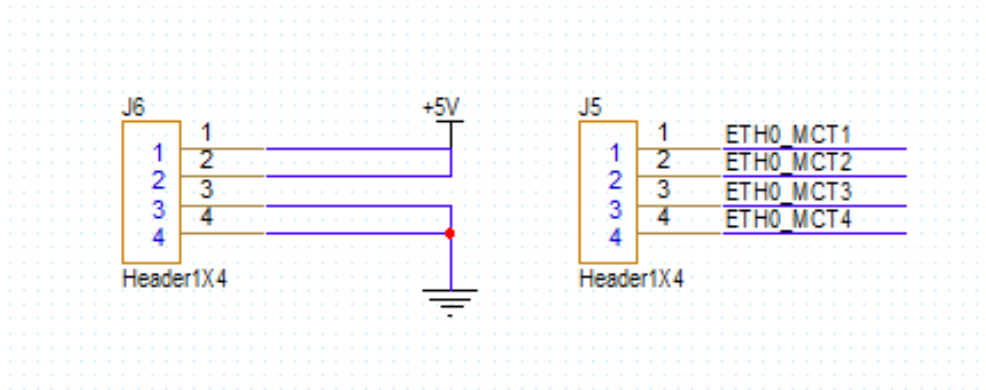

Figure 1: Power connector for RAK19018